

TRAILER SPECIFICATION

MAKE	Solacraft	COUPLING	50mm or ring coupling
MODEL	X6-MCM	TYRE/RIM	31 x 10.5 R 15 LT
TYPE	Single Solid Axle Solar	BRAKE	Over-ride cable w/ handbrake
TARE/AGG (kg)	1375 / 1500	L x W x H (mm)	4050 x 1781 x 2010
MAST	Vertical fixed, telescopic SHS	MAST WINCH	Brake Hand Winch
SOLAR	4 x 400w Sunpower MAX 3	REGULATOR	Victron Smart Solar 150 60
BATTERY	6 x 150Ah 12V Gel	CONNECTIVITY	Victron Connect

FEATURES

- Rugged single axle chassis with lockable ventilated battery enclosure
- Heavy-duty battery drawers for safe and easy access to batteries
- Internal mounting points for multiple IP66 rated equipment cabinets
- Victron Energy regulators with Bluetooth and VE.Connect remote access
- Rear forklift pockets and cyclone tie down points
- Hot dip galvanised chassis and powder coating on most components
- LED trailer lighting
- Heavy duty suspension and all terrain off road tyres
- 4 x heavy duty height adjustable outriggers (hand or power pack operation)
- Lockable Battery Isolation Switch
- 4 x Wheel Chocks mounted on wheel guards & Wheel Nut Indicators
- Optional second row battery tray to increase capacity up to 6 extra 170Ah Gel batteries
- Air filtration foam in ventilation openings
- 24V DC power with voltage conversion to suit any end user equipment

Industry leading high efficiency solar system

Drawbar FRP working platform

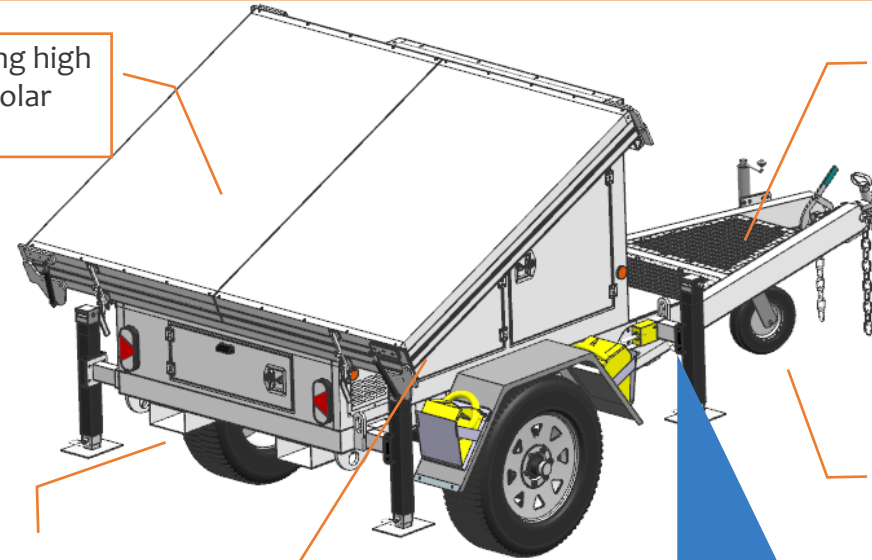

Rugged heavy-duty chassis

Forklift lifting pockets and cyclone tie down points

Heavy-duty battery drawers to improve access



Solacraft Australia

17 Townsend Street | Malaga | Western Australia | 6090



info@solacraft.com.au



www.solacraft.com.au